

MASTER LOCKING WHEEL NUT REMOVAL SET

IMPORTANT: PLEASE READ THESE INSTRUCTIONS CAREFULLY. NOTE THE SAFE OPERATIONAL REQUIREMENTS, WARNINGS & CAUTIONS. USE THE PRODUCT CORRECTLY AND WITH CARE FOR THE PURPOSE FOR WHICH IT IS INTENDED. FAILURE TO DO SO MAY CAUSE DAMAGE AND/OR PERSONAL INJURY AND WILL INVALIDATE THE WARRANTY. KEEP THESE INSTRUCTIONS SAFE FOR FUTURE USE.



Refer to Instructions



Wear eye protection



Wear protective gloves



Wear safety footwear

1. SAFETY

- WARNING! DO NOT** use the tool if damaged or thought to be faulty.
- WARNING!** Ensure that Health & Safety, Local Authority Regulations and general workshop practice Regulations are adhered to when using tools.
- DO NOT** use the tool for a task it is not designed to perform.
- DO NOT** use the tool unless you have been instructed in its use by a qualified person.
- DO NOT** operate the tool if you are tired or under the influence of alcohol, drugs or intoxicating medication.
- Maintain the tool in good condition.
- Follow all workshop safety rules, regulations and conditions.
- Wear eye protection, protective gloves and safety footwear.
- Maintain correct balance and footing. Ensure the floor is not slippery and wear non-slip shoes.
- Keep children and non essential persons away from the work area.

2. INTRODUCTION

Simple to use master kit has the capability of removing practically any locking wheel nuts. Kit includes shroud which protects the wheel against any damage. Very effective and a must have workshop tool.

3. SPECIFICATION

4. CONTENTS

No.	Part number	Description
1		Impact driver
2		Centre punch
3		Hand protection ring
4		Main body & outer shroud
5		Cutter C available in packs of 10
6		Cutter A
7		Cutter B
8		1/2" drive impact socket 24mm

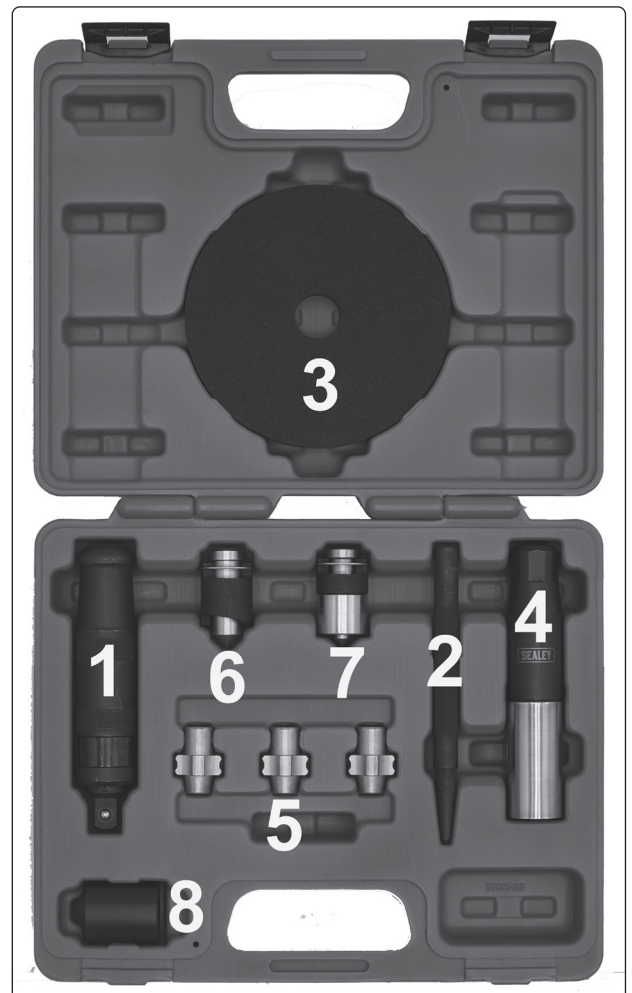

5. ASSEMBLY

5.1. CUTTER A AND MANDREL

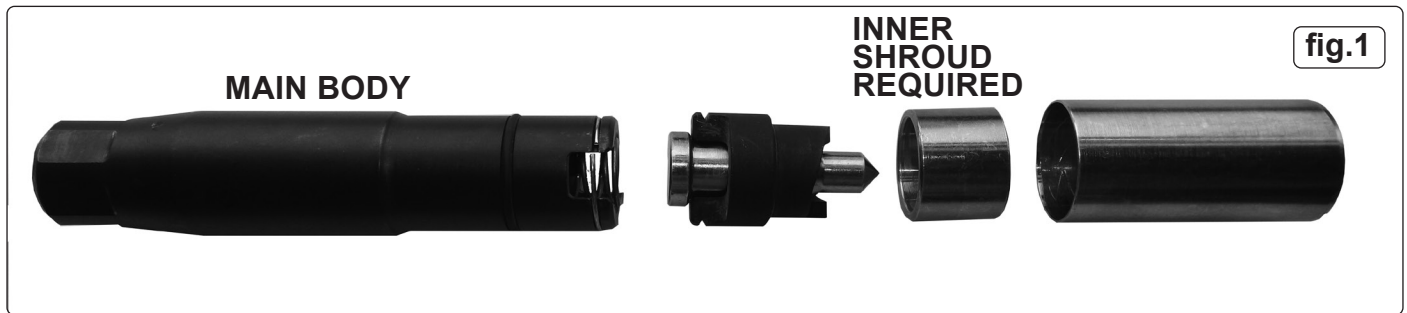

NOTE: Apply tape to outer shroud.

5.2. CUTTER B AND MANDREL

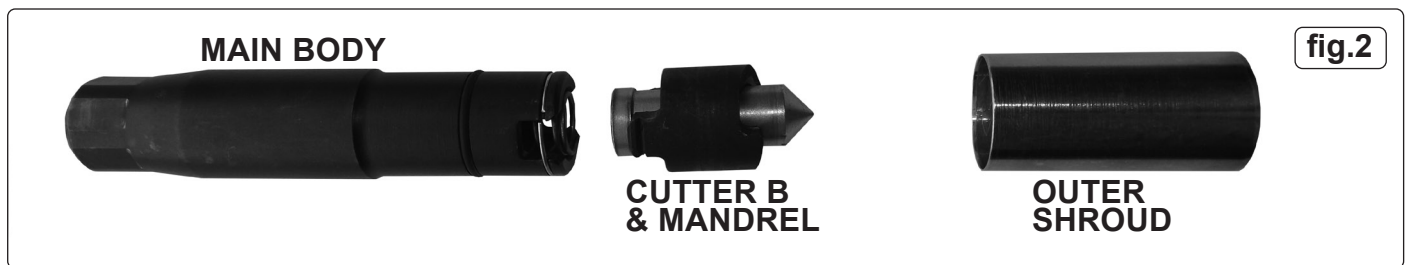

NOTE: Centre punch the nut when there is no hole present.

NOTE: Apply tape to outer shroud.

NOTE: Disposable Cutter (5) is required for this type of hardened nut. Cutters A & B will be damaged if used on hardened nuts.

5.2.1. ASSEMBLY

5.2.1.1. Separate outer shroud from main tool body.

5.2.1.2. Select the correct cutter to suit locknut/stud, refer to fig.3.

5.2.1.3. Make sure the spring is inside the main body and clip the cutter assembly into the tool body (secured by the spring ring.)

5.3. CUTTER C DISPOSABLE (see also Section 7)

NOTE: CUTTER C IS REQUIRED FOR THIS TYPE OF HARDENED NUT (AS SHOWN IN FIG.7)

5.3.1. Cutter C is designed to remove 2 sizes of lock nuts. Choose the end of Cutter C that best locates into the locknut pattern.

5.3.2. One end of the Cutter is designed to remove all 4 lock nuts on one vehicle.

6. OPERATION CUTTERS A & B

NOTE: All illustrations shown WITHOUT hand protection ring fitted. This should always be used.

6.1. Remove outer shroud from body.

6.2. Select correct cutter to suit lock nut type and wheel bolt recess size.

6.3. When using Cutter A: if the inner shroud will fit over the locknut when offered up to the wheel, this will help keep the tool centred.

6.4. Refit the outer shroud over the tool body (the outer shroud should protrude 5mm ahead of the tips of the cutter to provide a shield to the lock nut.

This will provide protection to the wheel. The lock nut/stud and the cutter are all inside the outer shroud.

6.5. Fit the hand protection ring over the end of the tool.

WARNING! Cutters A and B must not be used on hardened nuts or studs.

6.6. Use the centre punch provided to test the lock nut for hardness. Make sure that the rest of the wheel nuts are all fitted and tightened.

Where possible test the centre of the nut face.

6.7. **If the centre punch makes a pop mark without deforming** proceed as per instructions below.

6.8. **If the punch deforms/blunts -**

DO NOT USE CUTTERS A OR B AS DAMAGE TO THE CUTTERS WILL RESULT, see Section 7 Cutter C Operation.

6.9. **OPERATION CUTTERS A and B fig.4**

WARNING! Wear appropriate PPE: gloves, safety goggles and safety footwear.

6.9.1. The tool must be placed firmly against the lock nut face, inline, horizontal and in the centre of the lock nut.

6.9.2. The cutters must be held firmly against the lock nut face to prevent the tool bouncing away from the lock nut.

6.9.3. With a 3lb club hammer gradually build up the force of the applied to the tool until the teeth are driven into the lock nut face.

6.9.4. Let the tool do the job.

6.9.5. Maintain the contact between the cutter and the locknut and place the 24mm impact socket onto the main body.

6.9.6. Use either:

Quality air impact wrench, heavy duty impact driver (standard tool unsuitable), breaker bar, see below.

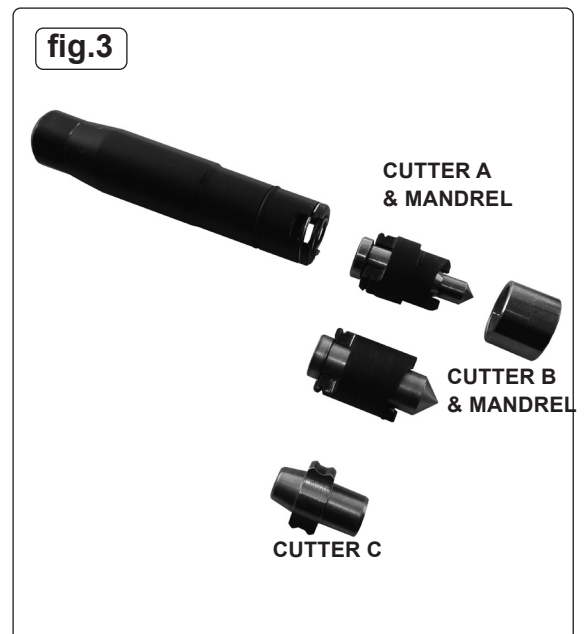



- 6.9.7. **USING AN AIR IMPACT WRENCH fig.5**
 6.9.7.1. This is the most preferable method of removal.
 6.9.7.2. If possible have the car raised on a ramp.
 6.9.7.3. The other wheel nuts need to be in place whilst problem wheel nut is being worked on.
NOTE: Keep the air impact wrench horizontal.
 6.9.7.4. Firmly push against the wheel nut to maintain contact with the lock nut.

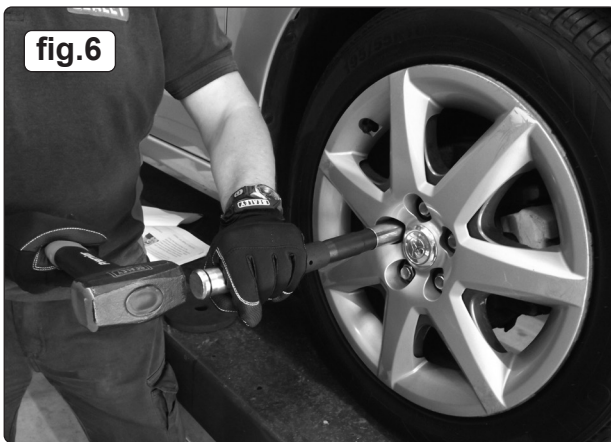

- 6.9.8. **USING SUPPLIED IMPACT DRIVER fig.6**
 6.9.8.1. Ensure the cutter blades are still located in the grooves made into the lock nut.
 6.9.8.2. Push the impact driver inwards and apply pressure in an anticlockwise direction, before each strike with a 3lb club hammer.
 6.9.9. **USING BREAKER BAR fig.7**
 6.9.9.1. Ensure inward pressure before applying downward pressure to the breaker bar.
 6.9.9.2. If the tool slips re-cut and try again.
NOTE: It is possible to support the tool with a small scissor jack. Use the assistance of a second person to push down on the bar. The other person pushes the tool into the locknut.

7. OPERATION CUTTER C

- 7.1. Cutter C is designed to remove the type of hardened nut shown in fig.8.
 7.2. Cutter C is designed to remove two sizes of lock nuts. Select the end that is a best fit for the lock nut pattern.
 7.3. One end of a Cutter C is used to remove all of the lock nuts on one vehicle.
 7.4. **CUTTER C ASSEMBLY**
 7.4.1. Insert Cutter C into the end of tool body and fit the outer shroud, refer to fig.3.
 7.4.2. Insert the tool into the wheel recess and hammer the tool into the lock nut pattern, see fig.8.
 7.4.3. Cutter C needs to be 'cut' to a minimum of 3mm, see fig.9.
 7.4.4. Always use Impact driver when possible to remove the locknut.



