

# Supalign by Teco Automatic Tyre Changer with Assistor Arm SA4000LVS + SA/HTB24

**JHM  
BUTT**  
Established 1971

## SPECIFICATIONS

- Outside Clamping: 11" - 24"
- Inside Clamping: 13" - 26"
- Max Wheel Diameter: 1100mm
- Working Air Pressure: 8 - 10 bar
- Motor Power: 200/230V - 1ph - 1.1 kW
- Rotation Speed: 7 rpm - 2V 6.5 - 13 rpm
- Dimensions: 1150 x 920 x 1000 mm



**ASSISTOR ARM**  
**VARIABLE SPEED**  
**LEVERLESS DESIGN**

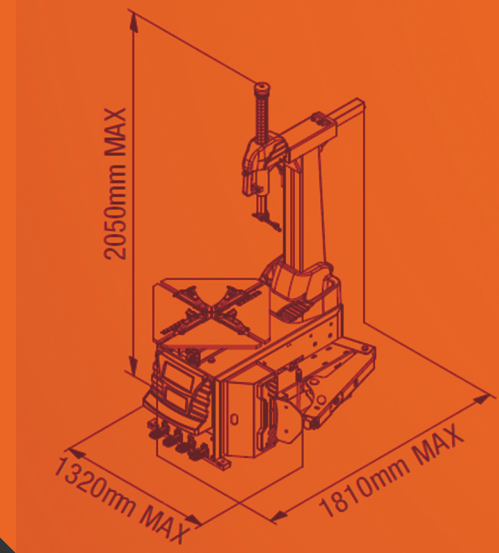

**YOUR ONE STOP SHOP FOR  
GARAGE EQUIPMENT & WORKSHOP TOOLS**  
01302 710868 [www.jhmbuttco.com](http://www.jhmbuttco.com)  
Brunel Industrial Estate, Brunel Cl, Harworth, Doncaster DN11 8QA